

THIS DRAWING IS UNPUBLISHED. RELEASED FOR PUBLICATION  
 © COPYRIGHT - By TYCO ELECTRONICS CORPORATION. ALL RIGHTS RESERVED.

LOC	DIST	REVISIONS			
P	LTR	DESCRIPTION	DATE	DWN	APVD
AF	50	N	REVISE PER ECR-13-013738	15FEB2014	GRZ JL

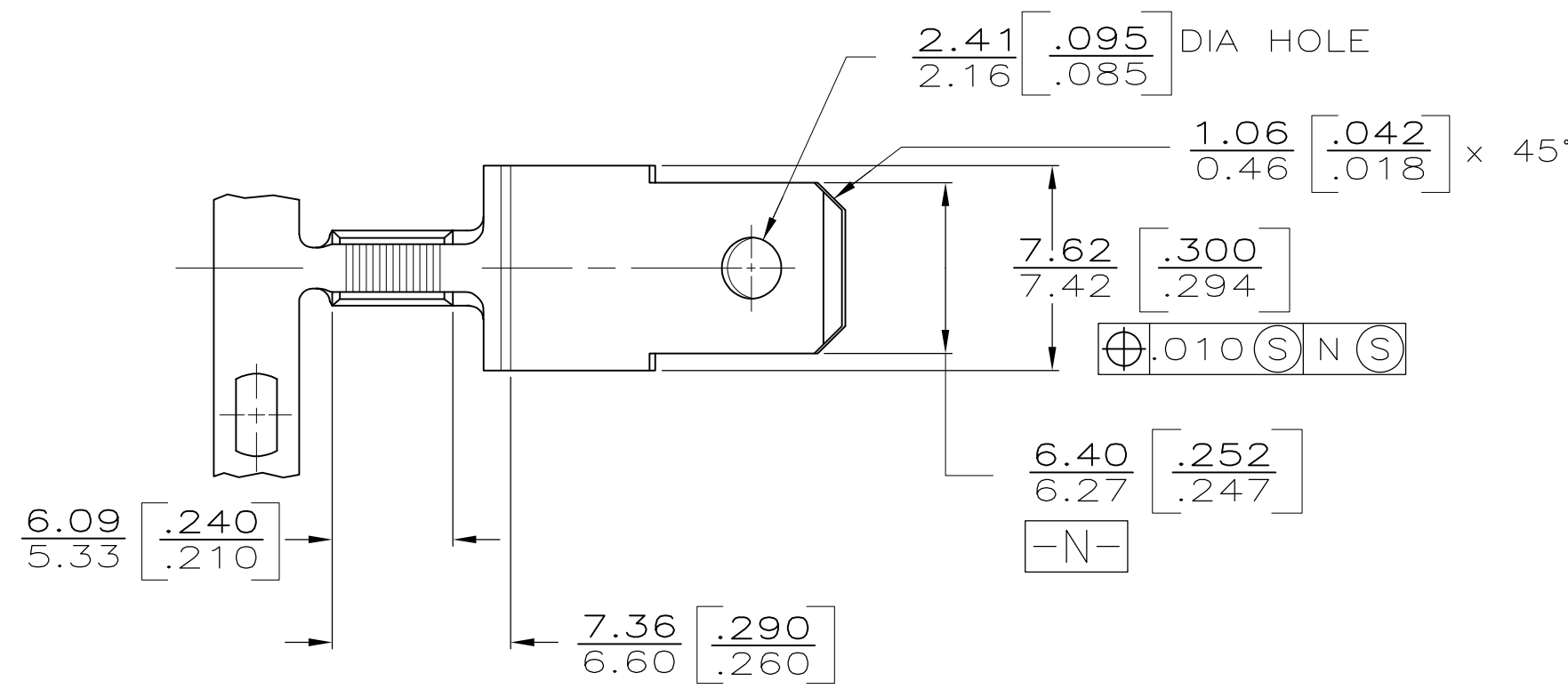

1- DIMENSIONS IN BRACKETS ARE IN INCHES.  
 2- CONTINUOUS STRIP ON REELS.

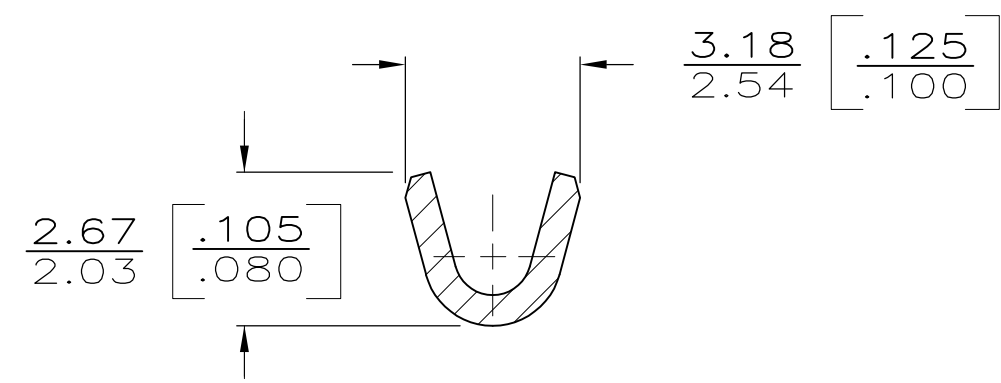
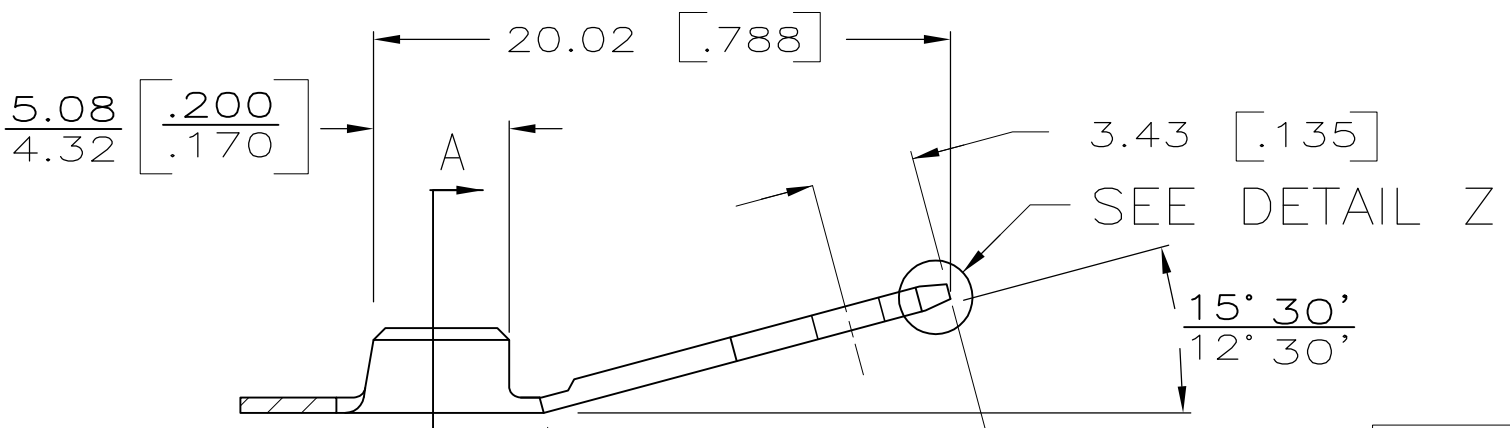

SECTION A-A

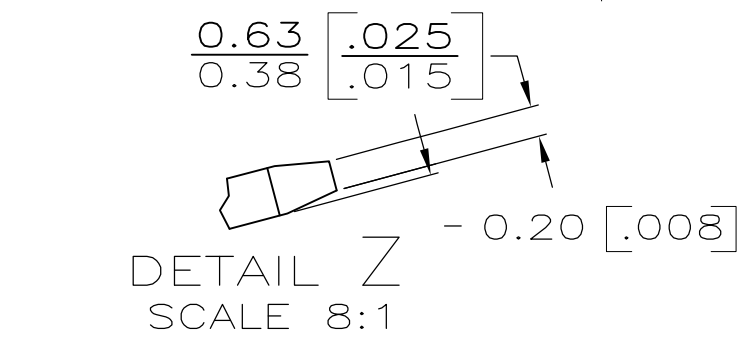

**METRIC**

REVERSE REEL	0.81 <sup>±0.025</sup> [.032] ±.001 PRE-MILLED	0.91-0.57 MM DIA	63165-2
	TO 0.51 <sup>±0.025</sup> [.020] ±.001	[19-23]	63165-1
REELING	MATERIAL	WIRE BARREL	PART NUMBER

THIS DRAWING IS A CONTROLLED DOCUMENT.		DWN JR RUTH 3-21-86	TE Connectivity .250 FASTON AMPLIVAR TAB		
DIMENSIONS: INCHES		CHK G YETTER 3-21-86			NAME
TOLERANCES UNLESS OTHERWISE SPECIFIED:		APVD C MEYERS 3-21-86			PRODUCT SPEC R KUZO 3-21-86
0 PLC ± - 1 PLC ± - 2 PLC ± - 3 PLC ± .010 4 PLC ± - ANGLES ± -		APPLICATION SPEC -			SIZE A3
MATERIAL BRASS	FINISH TIN	WEIGHT -	CAGE CODE 00779	DRAWING NO C-63165	RESTRICTED TO -
CUSTOMER DRAWING			SCALE NTS	SHEET 1 OF 1	REV N